



Part number

CAV 24.21



Brief description:

hoods for two levers, size "104.27", top entry, Pg21, metal version, IP66

Product description		Approvals / Standards	
Version	metal version	Quality mark	 (type:4/4X/12),  , EAC
Series	hoods for two levers	Conformity	CQC, CE
Product type	with 4 pegs	General ordering information	
Variant	top entry	EAN13 code	8015747010092
Style	high construction	Tariff number	85369095
Family	CLASS enclosures	Packaging Information	
Size	size "104.27"	Packaging length	240,00 mm
Technical data		Packaging height	150,00 mm
Material	metal	Packaging width	195,00 mm
IP degree of protection	IP66 (and IP69K DIN 40050 - 9)	Packaging weight	2,73 kg
Cable entry	Pg21	Packaging volume	7,02 dm ³
Further technical details		Packaging description	Carton box
Weight	273,00 g	Packaging quantity	10 Pcs
		Packaging EAN code	8015747010108
		Sub-packaging weight	1,37 kg
		Sub-packaging description	Plastic packaging
		Sub-packaging quantity	5 Pcs
		Sub-packaging EAN barcode	8015747010115

Part number

CAV 24.21



Catalogue drawings

**CHO [CAO] CHV (CAV) - MHO [MAO]
MHV (MAV)**

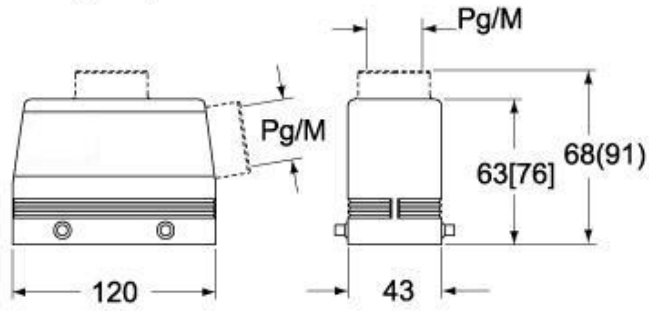

CHV G (CAV G) - MHV G (MAV G) - [MFV G]

